

16 HP VANGUARD™ Model Series 303700

Displacement 29.30 cu. in. (480 cc)

Bore 2.68 in. (68 mm)

Stroke 2.60 in. (66 mm)

Oil Capacity 48 fl. oz. (1.42 l) w/o Filter
56 fl. oz. (1.66 l) w/Filter



Features:

- Dura-Bore™ cast iron cylinder sleeve for extended life
- Dependable float feed type carburetor with integral fuel pump for remote mount fuel tank
- Maintenance-free Magnetron® electronic ignition for quick, dependable starts
- Dual-Clean™ air cleaner pleated paper filter with a foam pre-cleaner ensures maximum protection for extended engine life
- Full pressure lubrication with spin-on oil filter assures controlled lubrication for extended component life
- Overhead valve design (OHV) for cooler operation and longer valve life
- Buyer protection package provides two-year commercial engine warranty

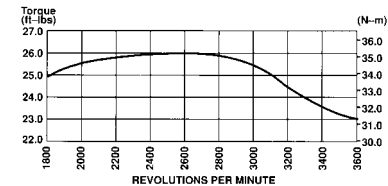
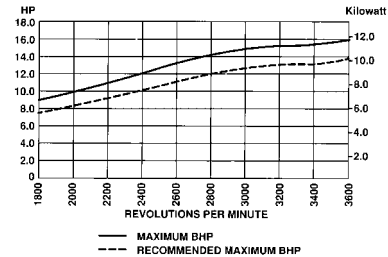
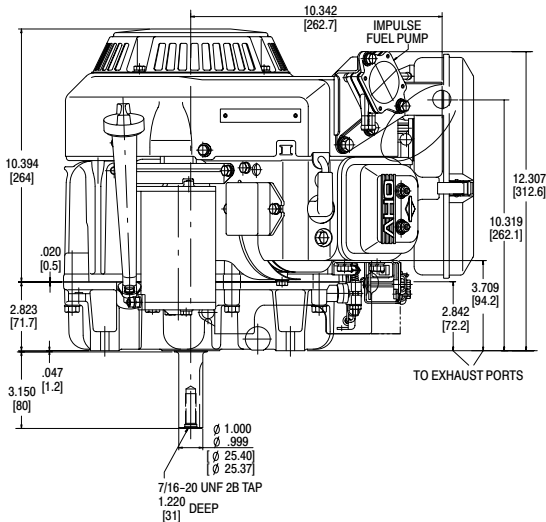
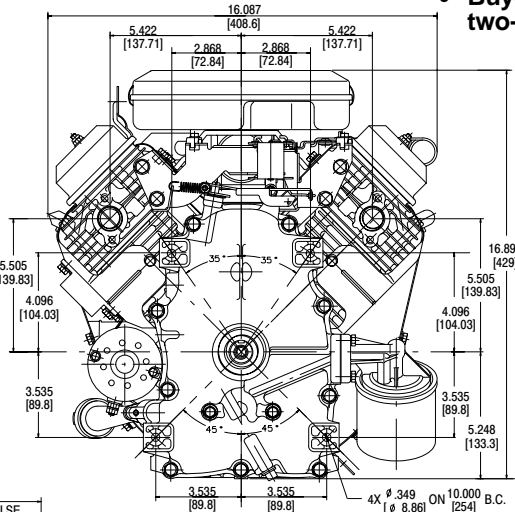
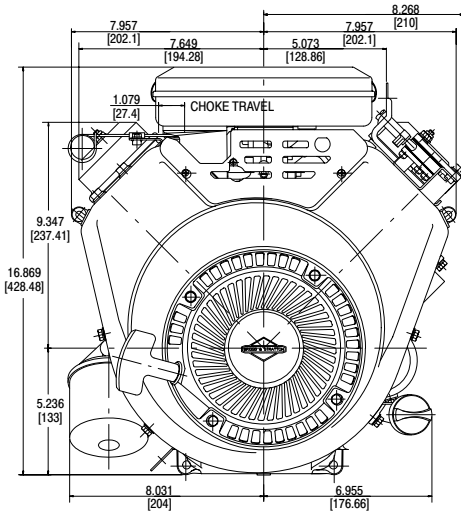

See Engine Accessories & Products Catalog Form MS-3880 for Exhaust Manifold and Muffler Options.